

Time Delay Relays – Multifunction

R65 Series



Features

- 10 Programmable Timing Modes + 2 Counting Modes
- 0.1 sec to 9,990 hr. Programmable Timing Range
- 1 to 99,900 Counting Range
- LCD Digital Display
- Thumbwheel Switches for Programming



Programmable, DPDT, 10 Amp, AC or DC, Multifunctional, Digital Time Delay Relay/Counter.

D46

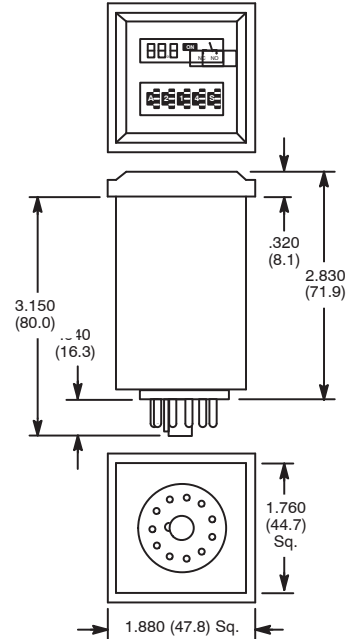

DPDT, 2 Form "C"

External Control Switches**

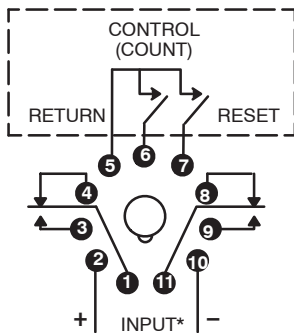

DPDT, 2 Form "C"

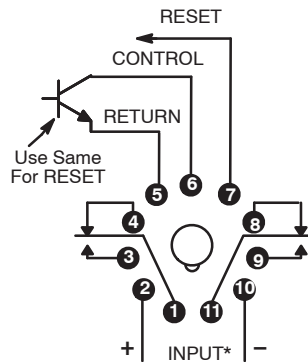

* Note input polarity for DC operation. For most reliable operation on AC, connect high side to "+" and low side to "-".

** **IMPORTANT:** A dry circuit switch is recommended. A "dry circuit" switch is one rated to reliably switch currents of less than 50mA. Use of a switch rated for other than dry circuit may result in failure of the time delay relay to function properly.

AC or DC OPERATED

NTE Type No.	Timing Adj Range	Count Range	Contact Arr.	Nom Vltg AC/DC	Nom Power	Max. Contact Cur. @ 28VDC 120VAC	Diag No.
R65-11AD10	0.1 Sec to 9,990 Hr.	1 to 99,900	DPDT	24 to 240	1W@24V 5W@120V 10W@240V	10A	D46

ACCESSORIES

MOUNTING STYLES	DESCRIPTION	NTE TYPE NO.
SURFACE MOUNT	11-PIN OCTAL	R95-104
PANEL MOUNT	11-PIN OCTAL	R95-119
DIN RAIL MOUNT	11-PIN OCTAL	R95-114
DIN RAIL MOUNT	11-PIN OCTAL	R95-182

Electrical Specifications

Contact

Rating: 10 Amps @ 30VDC or 277VAC, resistive;
1/2 HP @ 250VAC; 1/3 HP @ 120VAC
Life: 100,000 operations at minimum rated load
Mechanical Life: 10,000,000 operations

Input

Nominal Input voltage: 24 – 240V ±15%, 50/60Hz AC or DC
Nominal Power: See Chart

Timing

Timing Ranges: 0.1 to 99.9 / 1 to 999 sec; 0.1 to 99.9 / 1 to 999 min
0.1 to 99.9 / 1 to 999 / 10 to 9,990 hr.

Timing Adjustments: Digital adjustment via thumbwheel switches

Tolerance: ± 0.1% ± 0.05 sec

Delta Time (for AC units add ± 1 cycle 60Hz): ± 0.1% ± 0.05 sec

Repeatability: ± 0.1% ± 0.05 sec – including first cycle of operation

Reset Time (power interruption): 45mS, typ; 60mS, max

Minimum Pulse Width, Control: 50mS

Recycle Time: 45mS, typ; 60mS, max

Counting

Maximum Count: 1 to 999; 10 to 9,990 (÷ 10); 100 to 99,900 (÷ 100)

Maximum Count Rate: 100 counts per second

Minimum Pulse Width:

Count (Control): 3mS

Reset: 3mS

Available Counting Functions: Operate at preset count and release at preset count

Protection

Transient: yes

Dielectric Strength

Between Open Contacts: 1000V_{rms}, 60Hz

Between All Other Conductors: 1500V_{rms}, 60Hz

Environmental Characteristics

Operating: -10°C to +55°C





Storage: -20°C to +70°C

Weight

Std: 4.3 oz (122 grams) approx.

Time Delay Relays – Multifunction

Programming Switch Diagram

	  	
Function Select	Timer/Counter Select	Time Base Select
Timer Mode: A – Delay On Operate B – Delay On Release C – Interval On D – Control-Off Interval On E – Recycle F – Single Cycle G – Control On-Off Interval On H – Control On-Off Delay I – Pulse J – Cumulative Delay On Operate	001 to 999	Timer Base: .1S – 0.1 to 99.9 Sec S – 1 to 999 Sec .1M – 0.1 to 99.9 Min M – 1 to 999 Min .1H – 0.1 to 99.9 Hrs H – 1 to 999 Hrs 10H – 10 to 9990 Hrs
Counter Select		Counter Mode Select
Counter Mode: A, D-J – Normal Count B – Divide by 10 C – Divide by 100		CO – Operate at Preset Count CR – Release at Preset Count

NOTE: With this setting, the relay would operate after a delay period of 214 seconds.

Timer Function Descriptions

A. Delay On Operate

Output relay turned on at end of programmed time interval which is started by CONTROL input or power-on with CONTROL on. Relay turned off by RESET input until next cycle is started. With CONTROL on, turning RESET off restarts timing.

B. Delay On Release

Output relay turned on with CONTROL input and remains on for programmed time interval following removal of CONTROL. During time interval after release of CONTROL, RESET turns relay off until cycle restarted with reapplication of CONTROL. With CONTROL on, relay is held off while RESET is activated.

C. Interval On

Output relay turned on for programmed time interval by CONTROL or power-on with CONTROL on. RESET turns relay off until next cycle is started, and does not restart timing when RESET is removed.

D. Control-Off Interval On

Output relay turned on for programmed time interval by turn-off of CONTROL. RESET turns relay off until next cycle is started, and does not restart timing when RESET is removed.

E. Recycle

Output relay turned on at end of programmed time interval which is started by momentary CONTROL input or power-on with CONTROL on. Relay stays on for equal time interval, then turns off and cycle is repeated on a free-running basis until terminated by momentary RESET, turning relay off. With CONTROL on, turning RESET off restarts cycle.

F. Single Cycle

Output relay turned on at end of programmed time interval which is started by momentary CONTROL input or power-on with CONTROL

on. Relay stays on for equal time interval, then turns off. RESET terminates timing and turns relay off. Turning RESET off does not restart timing.

G. Control On-Off Interval On (Watch Dog Timer)

Output relay turned on and programmed time interval started or restarted by change of CONTROL input. RESET turns relay off and stops timing. Turning RESET off does not restart timing.

H. Control On-Off Delay

Output relay turned on at end of programmed timing interval which is started or restarted by change of CONTROL input. If relay is on, turn-off of relay occurs at end of programmed time interval which is started or restarted by change of CONTROL input. RESET turns relay off and stops timing. Turning RESET off does not restart timing.

I. Pulse

Output relay turned on at end of programmed time interval, which is started by CONTROL input, for 0.5 second duration, and continues in pulsed mode at programmed time interval with fixed 0.5 second on-time. Turning CONTROL off turns relay off and stops timing. RESET turns relay off and inhibits operation. With CONTROL on, removal of RESET restarts timing.

J. Cumulative Delay On Operate

Output relay turned on at completion of total accumulate CONTROL input duration equal to programmed time. Turning CONTROL off before accumulation of programmed time results in measured time total being held until CONTROL is again turned on and total programmed time value is reached. RESET input resets time value to zero and turns relay off if energized. Turning RESET off restarts timing if CONTROL is on.

Counter Function Descriptions

CO. Operate at Preset Count – Normal Mode

After initializing by momentary activation of RESET input, each on/off signal at COUNT (CONTROL) input increments displayed count in upcounting manner from initial 000 value until preset count, set by thumbwheel switches, is reached and output relay turns on. Additional inputs continue to increment displayed count. Continued counting past maximum count (999) results in a “wrap-around” effect to 000, followed by continued up-counting. Activation of RESET input turns relay off and resets count to zero.

CR. Release at Preset Count – Normal Mode

Initializing by momentary activation of RESET input turns relay on. Operation is similar to CO (Operate at Preset Count) except relay turns off at preset count.

CO or CR. Divide-by-10 Mode

Operation is as described previously, except count is incremented for every 10 on/off input signals for a maximum presettable count of 9,990.

CO or CR. Divide-by-100 Mode

Operation is as described previously, except count is incremented for every 100 on/off input signals for a maximum presettable count of 99,900.