

NTE7043 & NTE7043P Integrated Circuit Motor Driver ^{w/4} Modes

Features:

- 4 Modes Available: CW, CCW, STOP, and BRAKE
- Output Current Up to 1A (Average) and 2A (Peak)
- Wide Range of Operating Voltage:
 - $V_{CC\ opr} = 4.5V\ to\ 18V$
 - $V_S = 0\ to\ 18V$
 - $V_{ref} = 0\ to\ 18V$
- Built-In Thermal Shutdown, Overcurrent Protector, and Punch-Through Current Restriction Circuit
- Stand-By Mode Available: STOP Mode
- Hysteresis for All Inputs
- Two Package Styles Available:
 - NTE7043: 9-Lead SIP
 - NTE7043P: 10-Lead SIP ^{w/}Heat Sink Tab

Absolute Maximum Ratings: ($T_A = +25^\circ C$ unless otherwise specified)

Supply Voltage, V_{CC}	25V
Motor Drive Voltage, V_S	25V
Reference Voltage, V_{ref}	25V
Output Current, I_O	
NTE7043	
Average	400mA
Peak	1.2A
NTE7043P	
Average	1A
Peak	2A
Power Dissipation, P_D	
NTE7043 ($T_A = +25^\circ C$)	750mW
NTE7043P ($T_C = +25^\circ C$)	12.5W
Operating Temperature Range, T_{opr}	-30° to $+75^\circ C$
Storage Temperature Range, T_{stg}	-55° to $+150^\circ C$

Electrical Characteristics: ($T_A = +25^\circ\text{C}$, $V_{CC} = 12\text{V}$, $V_S = 18\text{V}$ unless otherwise specified)

Parameter	Symbol	Test Conditions	Min	Typ	Max	Unit	
Supply Current	I_{CC1}	Output OFF, CW/CCW Mode	–	8.0	13.0	mA	
	I_{CC2}	Output OFF, STOP Mode	–	0	0.05	mA	
	I_{CC3}	Output OFF, BRAKE Mode	–	6.5	10.0	mA	
Input Operating Voltage	V_{IN-H}	$T_J = +25^\circ\text{C}$	High	3.5	–	5.5	V
			Low	0	–	0.8	V
Input Current	I_{IN}	$V_{IN} = 3.5\text{V}$, Sink Mode	–	3	10	μA	
Input Hysteresis Voltage	V_{HYS}		–	0.7	–	V	
Saturation Voltage Upper Side	$V_{SAT\ U-1}$	$V_{ref} = V_S$, $V_{OUT} - V_S$, Measure $I_O = 200\text{mA}$, CW/CCW Mode	–	0.9	1.2	V	
	$V_{SAT\ L-1}$		–	0.8	1.2	V	
NTE7043 Upper Side	$V_{SAT\ U-2}$	$V_{ref} = V_S$, $V_{OUT} - V_S$, Measure $I_O = 400\text{mA}$, CW/CCW Mode	–	1.0	1.35	V	
	$V_{SAT\ L-2}$		–	0.9	1.35	V	
NTE7043P Upper Side	$V_{SAT\ U-3}$	$V_{ref} = V_S$, $V_{OUT} - V_S$, Measure $I_O = 1\text{A}$, CW/CCW Mode	–	1.3	1.8	V	
	$V_{SAT\ L-3}$		–	1.2	1.75	V	
Output Voltage NTE7043 (Upper Side)	$V_{SAT\ U-1}$	$V_{ref} = 10\text{V}$, $V_{OUT} - \text{GND}$, Measure $I_O = 200\text{mA}$, CW/CCW Mode	–	11.2	–	V	
	$V_{SAT\ U-2}$	$V_{ref} = 10\text{V}$, $V_{OUT} - \text{GND}$, Measure $I_O = 400\text{mA}$, CW/CCW Mode	10.4	10.9	12.2	V	
NTE7043P (Upper Side)	$V_{SAT\ U-3}$	$V_{ref} = 10\text{V}$, $V_{OUT} - \text{GND}$, Measure $I_O = 500\text{mA}$, CW/CCW Mode	–	11.0	–	V	
	$V_{SAT\ U-4}$	$V_{ref} = 10\text{V}$, $V_{OUT} - \text{GND}$, Measure $I_O = 1\text{A}$, CW/CCW Mode	10.2	10.7	12.0	V	
Leakage Current Upper Side	I_{L-U}	$V_S = 25\text{V}$	–	0	50	μA	
			Lower Side	I_{L-L}	$V_S = 25\text{V}$	–	0
Diode Forward Voltage Upper Side	V_{FU-1}	$I_F = 400\text{mA}$	NTE7043	–	1.5	–	V
			NTE7043P	–	2.5	–	V
	V_{FL-1}	$I_F = 400\text{mA}$	NTE7043	–	0.9	–	V
			NTE7043P	–	1.2	–	V
Reference Current	I_{ref}	$V_{ref} = 10\text{V}$, Source Mode	–	20	40	μA	

Function Table:

Input		Output		Mode
IN 1	IN 2	OUT 1	OUT 2	
0	0	∞	∞	STOP
1	0	H	L	CW/CCW
0	1	L	H	CCW/CW
1	1	L	L	BRAKE

Note 1. Inputs are all high active type.

Note 2. ∞: High impedance

**Pin Connection Diagram
NTE7043
(Front View)**

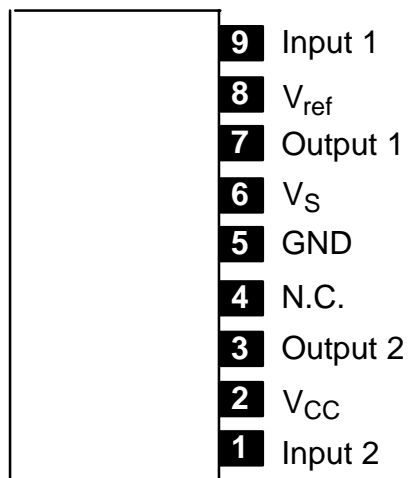

**NTE7043P
(Front View)**

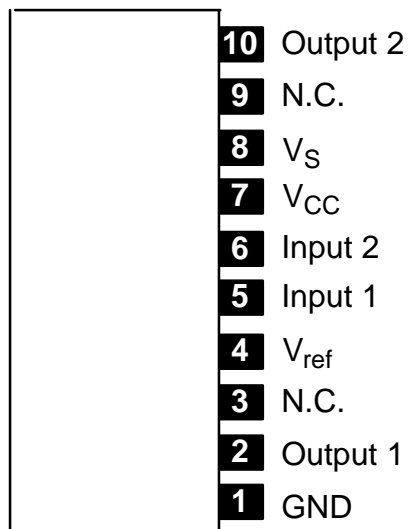

NTE7043

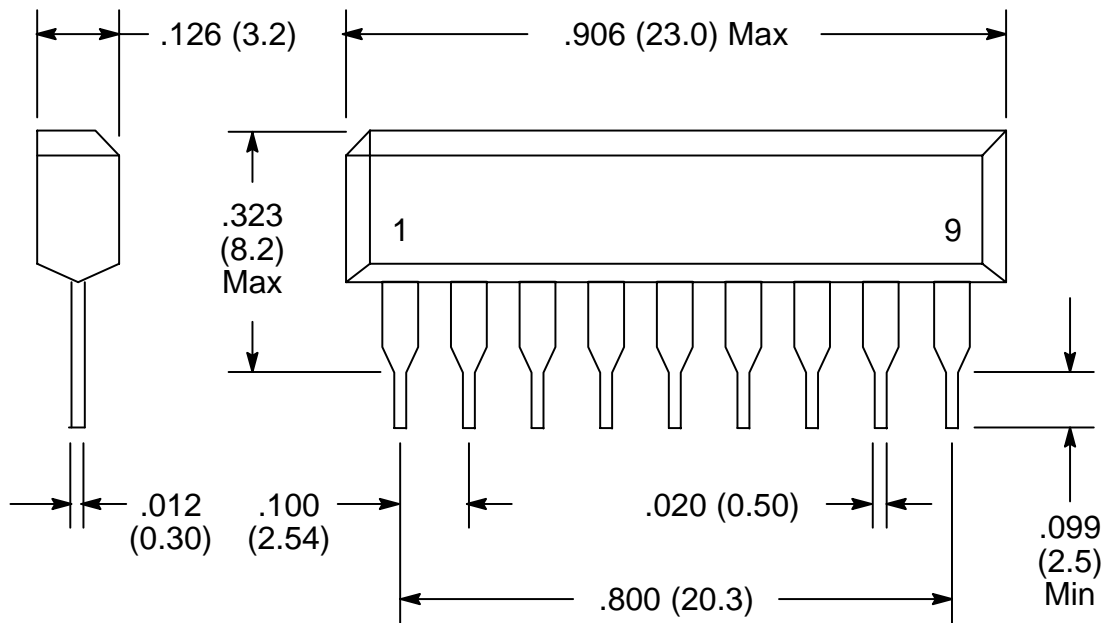

NTE7043P

